

Rough Machining with Tangential Technology

NEW

Ø 52,5 – 3255 mm

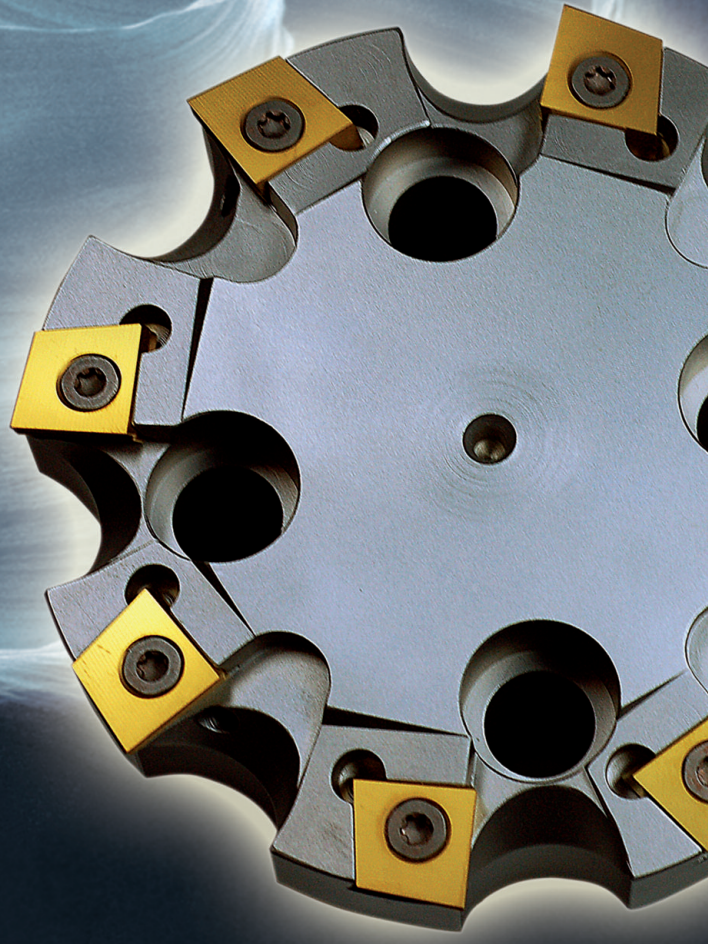

WOHLHAUPT

Für Ihren Erfolg.

Rough machining with Tangential Technology



As one of the world's first tool manufacturers, Wohlhaupter has been deploying twin cutter tools with tangentially installed replaceable inserts in the drilling machining area for decades now. If, during the course of the past few years the move "towards ISO shapes" when turning

tended to overshadow tangential replaceable inserts, the trend nowadays has swung all the way back to tangential tools for drilling machining.

A ground rake shape, combined with a highly positive rake angle, provides a smoother cut and therefore a lower torque. This results in larger cutting depths and a smoother cutting characteristic. This in turn means that the tools can be used on machines with lower drive power. If tangential technology is also used for special tools, then more cutting edges can be used in the tool and therefore feeds can be increased, and machining times drastically reduced.

Wohlhaupter is the only provider to offer a comprehensive modular product range of drilling tools for rough machining using tangential replaceable inserts – and it is available immediately from the warehouse.

The combination of powerful twin cutter tools and tangential replaceable inserts provide the machinist with maximum productivity coupled with low tool costs. If, as an alternative, this replaceable insert technology is installed in customer-specific solutions, the performance potential can then be fully developed. In both instances – be it standard tools or special solutions – Wohlhaupter is always your best partner when it comes to the efficient machining of holes.

Put us to the test!



Example: Machining pressure plates for plastic injection molding machines

Boring Ø:	378 mm
Replaceable inserts:	Form 05: 4 x F005 05 GL 880, WHC 05
Over-allowance:	32.0 mm in diameter*
Connection:	D 60
Total tool length:	580 mm (SK 60 with spindle extension)
Material:	GGG 60
Vc	130 m/min.
n	160 rpm
Vf	132 mm/min.
fz	0.15 mm/rev.
Cut distribution	2 x Z = 2

Using this special tool enables the machining process to be realized with one tool instead of what were previously three tools. Machining time: Approx. 13 minutes.

* The stable machining conditions mean that our recommended ap value (up to 6.0 mm) is clearly exceeded by an ap value of = 8.0 mm.

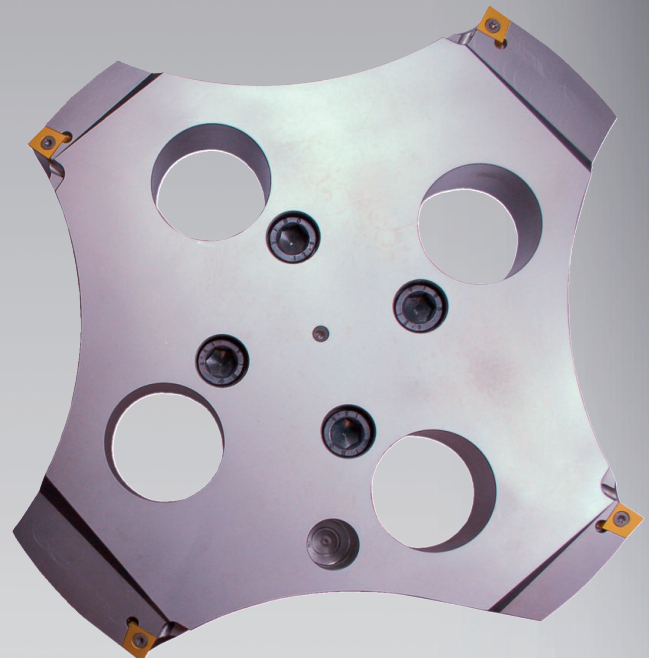

WOHLHAUPTER

Für Ihren Erfolg.

Boring tools for rough machining with tangential insert holders

VARIO LINE

without function module
same level cutting,
Ø 52,5 – 113 mm, 90°

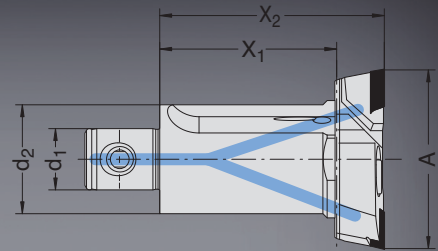

MVS-connection	Boring range		Serrated tool body			Insert holder	Insert form	Complete tool	Cap screw with boring* Order No.
	d ₂ d ₁	A	X ₁	X ₂	kg				
32 - 18	52,5 - 59,0	66	52,0	0,4	435 003	436 043	04	437 015	435 203
40 - 22	58,5 - 74,0	75	57,5	0,7	435 004	436 044	04	437 016	435 203
40 - 22	68,0 - 83,5	75	57,5	0,7	435 004	436 034	05	437 017	435 203
50 - 28	71,0 - 89,0	75	57,5	1,1	435 005	436 045	04	437 018	435 205
50 - 28	82,0 - 100,0	75	57,5	1,2	435 005	436 035	05	437 019	435 205
63 - 36	82,0 - 103,0	90	68,0	2,1	435 006	436 046	04	437 020	435 206
63 - 36	92,0 - 113,0	90	68,0	2,2	435 006	436 036	05	437 021	435 206

* for optimum boring of blind holes (accessories)

Twin cutter tools,
same level cutting,
Ø 53 – 205 mm,
90°

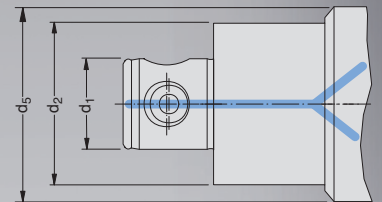
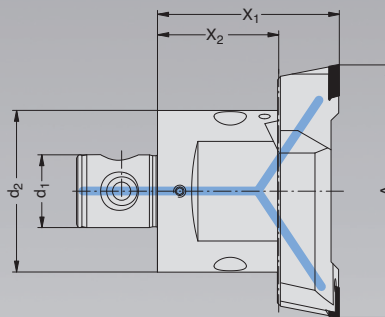

MVS-connection	Boring range		Serrated tool body			Insert holder	Insert form	Complete tool	
	d ₂ d ₁	A	X ₁	X ₂	d ₅ kg				Order No.
40 - 22	53 - 66	75	55	-	0,7	148 004	151 022	04	155 071
50 - 28	65 - 83	75	55	-	1,0	148 005	151 032	04	155 072
50 - 28	65 - 83	75	55	-	1,0	148 005	151 043	05	155 073
63 - 36	82 - 103	90	60	-	2,0	148 006	151 034	04	155 074
63 - 36	82 - 103	90	60	-	2,0	148 006	151 035	05	155 075
80 - 36	100 - 130	90	60	-	3,0	148 007	151 009	05	155 020
80 - 36	125 - 155	90	60	-	3,2	148 007	151 010	05	155 021
80 - 36	150 - 205	90	60	125	4,0	148 009	151 010	05	155 022

ALU LINE

80 - 36	100 - 130	90	60	-	1,7	348 007	151 009	05	346 001
80 - 36	125 - 155	90	60	-	1,8	348 007	151 010	05	346 002
80 - 36	150 - 205	90	60	125	2,1	348 009	151 010	05	346 003

Tangential insert holders for slide range Ø 200 – 3255 mm

Tangential insert holder
same level cutting, 90°

Insert form	X ₁			kg	Order No.
05	30			0,6	149 010

Tangential insert holder
height-adjustable, 90°

Insert form	Connection ①	Adjuster screw ②	Insert holder ③	Fixing screw ④	Insert holder adjustable, complete
Order No.	Order No.	Order No.	Order No.	Order No.	Order No.
05	149 055	315 355	149 085	070 369	149 086

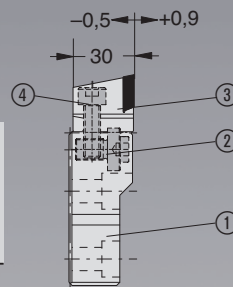
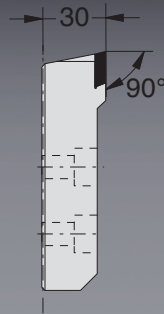

Example: Multistage drilling tool

Boring dia.:	118,0 mm
Replaceable insert:	Form 05: 8 x F005 05GL880 WHC05
Approach angle:	85°
Connection:	HSK-A 100
Machining material	GGG 60
Strength	600 – 750 N/mm ²
Hardness	200 – 250 HB
V _c	110 m/min.
n	296 min ⁻¹
f	1.0 mm/U
V _f	296 mm/min.
f _z	0.125 mm/U
a _p	7.5 mm





WOHLHAUPTER

Für Ihren Erfolg.

Wohlhaupter

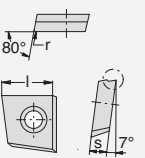
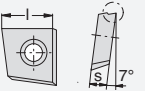
Tangential replaceable inserts

Form 04		Order No.	Carbide grade	Edge length, mm	Radius, mm	Tolerance group	Cutting direction	Availability	P	M	K	N
												
811		F004 05 GL 811 WHC05		10,5	0,5	G	left	<input type="checkbox"/>			○ ○	▼
880		F004 03 GL 880 WHC05		10,5	0,3	G	left	<input type="checkbox"/>	○ ○	○ ○	○ ○	▼
		F004 05 GL 880 WHC05		10,5	0,5	G	left	<input type="checkbox"/>	○ ○	○ ○	○ ○	▼
882		F004 08 GL 882 WHC05		10,5	0,8	G	left	<input type="checkbox"/>	○ ○	○ ○	○ ○	▼
885		F004 03 GL 885 WHC18		10,5	0,3	G	left	<input type="checkbox"/>				○ ○

Form 05		Order No.	Carbide grade	Edge length, mm	Radius, mm	Tolerance group	Cutting direction	Available	P	M	K	N
												
811		F005 05 GL 811 WHC05		14,5	0,5	G	left	<input type="checkbox"/>			○ ○	▼
880		F005 05 GL 880 WHC05		14,5	0,5	G	left	<input type="checkbox"/>	○ ○	○ ○	○ ○	▼
		F005 10 GL 880 WHC05		14,5	1,0	G	left	<input type="checkbox"/>	○ ○	○ ○	○ ○	▼
882		F005 10 GL 882 WHC05		14,5	1,0	G	left	<input type="checkbox"/>	○ ○	○ ○	○ ○	▼
885		F005 05 GL 885 WHC18		14,5	0,5	G	left	<input type="checkbox"/>				○ ○

Cutting recommendation			Form 04	Form 05
Steel	P	Vc (m/min.)	120 – 250	120 – 250
		fz (mm)	0,12 – 0,25	0,15 – 0,35
		ap (mm)	0,6 – 3,0	1,0 – 5,0
Stainless steels	M	Vc (m/min.)	80 – 160	80 – 160
		fz (mm)	0,12 – 0,20	0,15 – 0,30
		ap (mm)	0,6 – 2,5	1,0 – 4,0
Cast iron	K	Vc (m/min.)	140 – 250	140 – 250
		fz (mm)	0,12 – 0,25	0,15 – 0,35
		ap (mm)	0,6 – 3,0	1,0 – 6,0
Aluminium alloy	N	Vc (m/min.)	300 – 600	300 – 600
		fz (mm)	0,12 – 0,25	0,15 – 0,40
		ap (mm)	0,6 – 3,0	1,0 – 6,0

- Smooth cut
- Smooth cut, limited use
- Discontinuous cut
- Discontinuous cut, limited use
- ▼ Roughing
- ▼ Roughing, limited use
- Ex stock

WOHLHAUPTER

Für Ihren Erfolg.

Wohlhaupter Range

WOHLHAUPTER
Für Ihren Erfolg.

Systemwerkzeuge
System tools
Système d'outils



MULTI BORE

90100005.010

WOHLHAUPTER
Für Ihren Erfolg.

Wendeschneidplatten
Replaceable inserts
Plaquettes de coupe



WOHLHAUPTER
Für Ihren Erfolg.

Spannzeuge
Clamping tools
Outils de serrage

- HSK DIN 69803
- DIN 69 571-A/-AD/-B
- DIN 2080
- MAS-BT



WOHLHAUPTER
Für Ihren Erfolg.

Modulares Drehwerkzeugsystem
Modular Turning Tool System
Système Modulaire de Tournage

Modular turning Tool System **MTS**



HSK-T

6940102.011

Kundenspezifische Lösungen
Customised solutions
Solutions sur mesure



WOHLHAUPTER
Für Ihren Erfolg.

Einstechkopf **EK**
Grooving head
Tête pour exécution de gorges

Die bahnbrechende Innovation für Einstechoperationen.
The trail-blazing innovation for grooving operations.
Une innovation majeure pour l'exécution de gorges.



WOHLHAUPTER
Für Ihren Erfolg.

Plan- und Ausdrehköpfe **UPA**
Facing and boring heads
Tête à dresser et à aléser



WOHLHAUPTER
Für Ihren Erfolg.

WOHLHAUPTER

Für Ihren Erfolg.

Wohlhaupter GmbH Präzisionswerkzeuge
Maybachstraße 4 • 72636 Frickenhausen
Postfach 1264 • 72633 Frickenhausen
Tel. +49 (0)7022 408-0 • Fax +49 (0)7022 408-212
www.wohlhaupter.com • E-Mail: info@wohlhaupter.de

Certified
Quality Management
goes without saying
with Wohlhaupter

Zertifikat

kdwa
Kundenzufriedenheit

Wohlhaupter GmbH
Präzisionswerkzeuge
Maybachstraße 4
72636 Frickenhausen
Tel. +49 (0)7022 408-0
Fax +49 (0)7022 408-212
www.wohlhaupter.com

ISO 9001:2008
Zertifiziert

ISO 9001:2008
Zertifiziert

ISO 9001:2008
Zertifiziert

ISO 9001:2008
Zertifiziert